

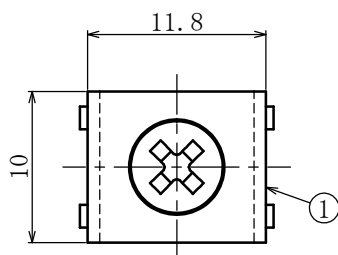

| | | | |
|--------------------------------------|------------------|--------------------|--------------------|
| 型名 Type Number | F4051A | | |
| 定格 Rating | 20A~40A | | |
| ねじ径 Screw Diameter | M3 | | |
| 使用可能電流 Usable Current | 20A | 30A | 40A |
| 適合電線 Compatible Wire | 2mm ² | 3.5mm ² | 5.5mm ² |
| 推奨圧着端子 Recommended Crimp Terminal | ※R2-3 | ※R3.5-4 | ※R5.5-3S |

一般公差 / General Tolerance ±0.5

尺度 / Scale $\frac{2}{1}$ 単位 / Unit mm



※適合電線2mm², 3.5mm²及び5.5mm²使用時の圧着端子は“R2-3”, “R3.5-4”及び“R5.5-3S”で使用可能

The crimp terminal when using the compatible wires

2, 3.5 and 5.5mm² can be used with “R2-3”, “R3.5-4” and “R5.5-3S”.

推奨圧着端子はニチフ(株)の圧着端子を基に選定しています。

The crimp terminals are selected based on the crimp terminals from Nichifu Co., Ltd.

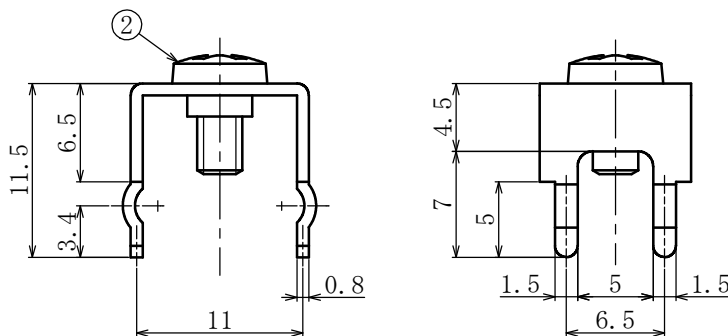

基板加工参考例
Processing the reference printed board

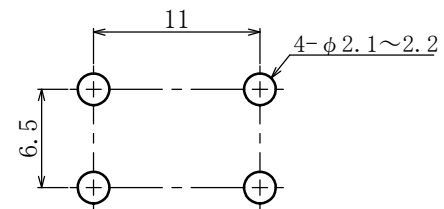

プリント基板厚: t1.4~2.0
Printed board: t1.4~2.0

・注文方法: **型番** (下表の型番を御参照下さい。)

・Ordering Form: Type No. (See the type number in the following table)

仕様 Specifications

| 番号 Part No. | 名称 Part Name | 材質 Material | 寸法 Size | 規格 Standard | 処理 Treatment |
|-------------|-----------------------------|-------------|----------|-------------|-----------------------|
| 1 | 基板端子 Printed board Terminal | 黄銅 Brass | 板厚 t=0.8 | C2680R | スズメッキ Tin-Plated |
| 2 | 結線ビス Screw | 黄銅 Brass | M3 | C2700W | ニッケルメッキ Nickel-Plated |

| 型番 Type No. | 納入される物 Product Delivered | |
|-------------|---------------------------|-----------------------------------------------------------|
| F4051A | 基板端子(M3用)のみ(ビスなし) | Printed board terminal (for M3) only (W/0 screws) |
| F4051AS | 基板端子+M3×6Lバインドビス(Type⑧)組付 | Printed board terminal+M3×6L binding head(Type⑧) attached |

| 対応可能ビス Compatible screw | 材質 Material | 処理 Treatment | 形状 Shape |
|-----------------------------------------------------------------------------------|-------------|-----------------------|----------|
| PW・SWセムスパインド M3×6L Type③With Plain(Flat)washer and spring lock washer M3×6L | 黄銅 Brass | ニッケルメッキ Nickel-Plated | Type③ |
| | 鉄 steel | | |
| SWセムスパインド M3×6L Type④With spring lock washer M3×6L | 黄銅 Brass | ニッケルメッキ Nickel-Plated | Type④ |
| PW・SWセムスナベ M3×7L Type⑤With Plain(Flat)washer and spring lock washer M3×7L | 黄銅 Brass | ニッケルメッキ Nickel-Plated | Type⑤ |
| | 鉄 steel | | |
| SWセムスナベ M3×7L Type⑦With spring lock washer M3×7L | 黄銅 Brass | ニッケルメッキ Nickel-Plated | Type⑦ |