

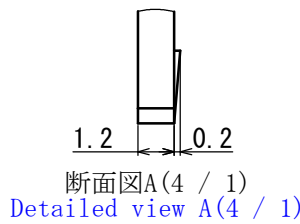

型名 Type Number	F 4 1 2 8 D
定格 Rating	1 0 0 A
ねじ径 Screw Diameter	M 5
使用可能電流 Usable Current	1 0 0 A
適合電線 Compatible Wire	3 8 mm <sup>2</sup>
推奨圧着端子 Recommended Crimp Terminal	R 3 8 - 5

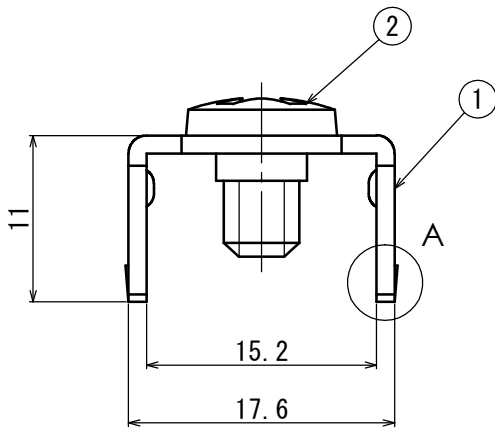

一般公差 / General Tolerance ±0.5  
尺度 / Scale  $\frac{2}{1}$  単位 / Unit mm

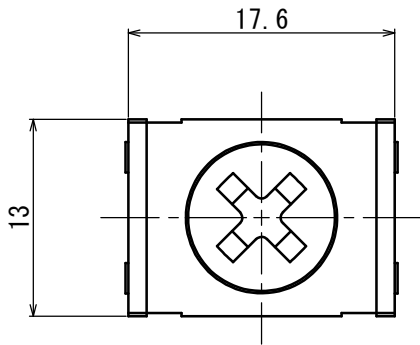
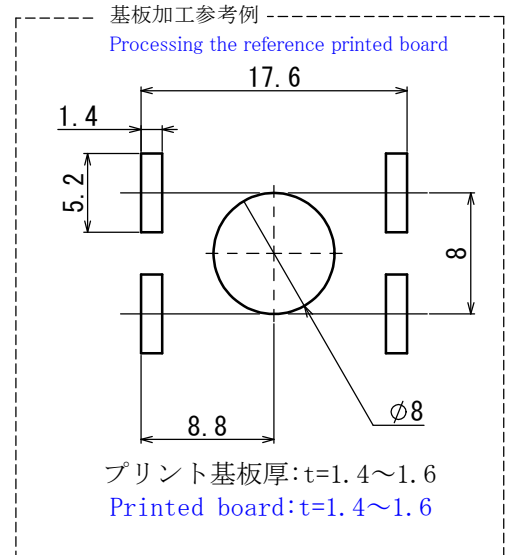

・注文方法: **型番** (下表の型番を御参照下さい。)

■仕様 Specifications. ・Ordering Form: Type No. (See the type number in the following table)

番号 Part No.	名称 Part Name	材質 Material	寸法 Size	規格 Standard	処理 Treatment
1	基板端子 Printed board Terminal	黄銅 Brass	板厚 t=0.8	—	スズメッキ Tin-Plated
2	結線ビス Screw	黄銅 Brass	M5	—	ニッケルメッキ Nickel-Plated

型番 Type No.	納入される物 Product Delivered
F4128D	基板端子のみ(ビスなし) Printed board terminal (for M5) only (w/o screws)
F4128DS	基板端子M5×8Lバインドビス(Type③)組付 Printed board terminal+M5×8L binding head attached (Type③)

対応可能ビス Compatible screw	材質 Material	処理 Treatment	形状 Shape
PW, SWセムスパインド M5×8L Type③With Plain(Flat)washer and spring lock washer M5×8L	黄銅 Brass	ニッケルメッキ Nickel-Plated	Type③
	鉄 steel		
PW, SWセムスナベ M5×9L Type⑤With Plain(Flat)washer and spring lock washer M5×9L	黄銅 Brass	ニッケルメッキ Nickel-Plated	Type⑤
	鉄 steel		