

基板端子



Printed board Terminal



型名 Type Number	F 4 1 3 2 A		
定格 Rating	2 0 A ~ 4 0 A		
ねじ径 Screw Diameter	M 3		
使用可能電流 Usable Current	2 0 A	3 0 A	4 0 A
適合電線 Compatible Wire	2 mm ²	3. 5 mm ²	5. 5 mm ²
推奨圧着端子 Recommended Crimp Terminal	R 2-3	※R 3. 5-4	※R 5. 5-3N

一般公差/General Tolerance ±0.5

尺度²/₁Scale²/₁ 単位/Unit mm

※適合電線3.5mm², 5.5mm²使用時の圧着端子は“R3.5-4”, “R5.5-3N”で使用可能

The crimp terminal when using the compatible wires 3.5mm² and 5.5mm² can be used with “R3.5-4” and “R5.5-3N”.

推奨圧着端子はニチフ(株)の圧着端子を基に選定しています。

The crimp terminals are selected based on the crimp terminals from Nichifu Co., Ltd.

基板加工参考例

Processing the reference printed board

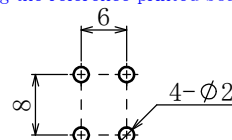

プリント基板厚:t=1.4~2.0
Printed board:t=1.4~2.0

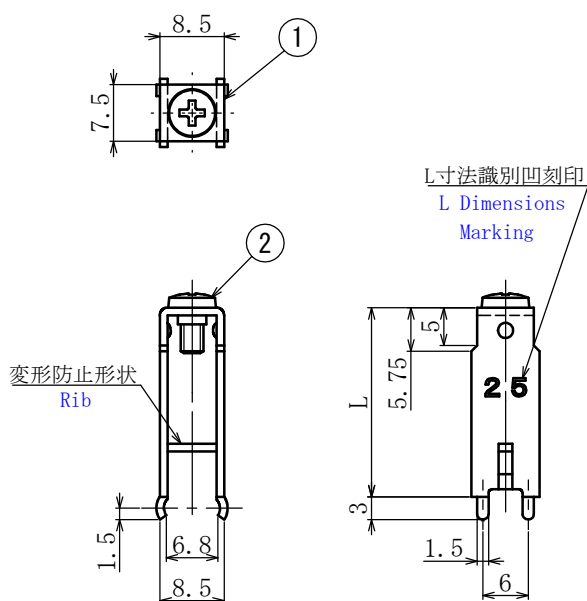

※結線する際は、必ず厚み1mm以上の圧着端子、プリント基板等の板を挟みねじを締付けること。

※When connecting, be sure to sandwich a plate as a crimp terminal or printed circuit board with a thickness of 1 mm or more and tighten the screws.

・注文方法: 型番 --- (下表の型番を御参照下さい。)

・Ordering Form: Type No. (See the type number in the following table)

仕様 Specifications

番号 Part No.	名称 Part Name	材質 Material	寸法 Size	規格 Standard	処理 Treatment
1	基板端子 Printed board Terminal	銅 Copper	板厚 t=0.8	C1100	スズメッキ Tin-Plated
2	結線ビス Screw	黄銅 Brass	M3	C2700W	ニッケルメッキ Nickel-Plated

型番 Type No.	納入される物 Product Delivered
F4132A-15L	基板端子 (M3用)のみ(ビス無し) Printed board terminal (for M3) only (w/o screw)
F4132A-20L	
F4132A-25L	
F4132A-30L	
F4132A-35L	
F4132A-40L	
F4132A-45L	
F4132AS-15L	基板端子+M3×6Lバインドビス組付 Printed board terminal+M3×6L binding head attached
F4132AS-20L	
F4132AS-25L	
F4132AS-30L	
F4132AS-35L	
F4132AS-40L	
F4132AS-45L	

対応可能ビス Compatible screw	材質 Material	処理 Treatment	形状 Shape
PW, SWセムスパインド M3×6L Type③With Plain(Flat)washer and spring lock washer M3×6L	黄銅 Brass	ニッケルメッキ Nickel-Plated	Type③
	鉄 steel		
SWセムスパインド M3×6L Type④With spring lock washer M3×6L	黄銅 Brass	ニッケルメッキ Nickel-Plated	Type④
PW, SWセムスナベ M3×7L Type⑤With Plain(Flat)washer and spring lock washer M3×7L	黄銅 Brass	ニッケルメッキ Nickel-Plated	Type⑤
	鉄 steel		
SWセムスナベ M3×7L Type⑦With spring lock washer M3×7L	黄銅 Brass	ニッケルメッキ Nickel-Plated	Type⑦