

型名 Type Number	F 4 1 4 6 H		
定格 Rating	15 A ~ 30 A		
ねじ径 Screw Diameter	Φ 3. 6		
使用可能電流 Usable Current	15 A	20 A	30 A
適合電線 Compatible Wire	1.25 mm <sup>2</sup>	2 mm <sup>2</sup>	3.5 mm <sup>2</sup>
推奨圧着端子 Recommended Crimp Terminal	R 1.25-4	R 2-4	R 3.5-4

一般公差 / General Tolerance ±0.5

尺度 / Scale 2/1 単位 / Unit mm

基板加工参考例  
Processing the reference printed board

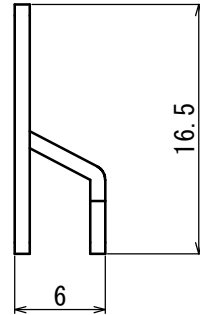
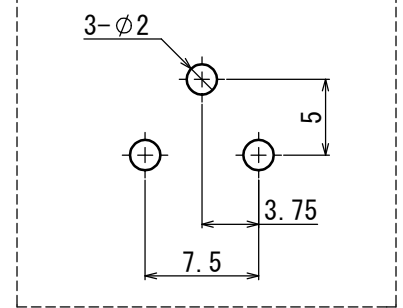

・注文方法: 型番 (下表の型番を御参照下さい。)

■仕様 Specifications. ・Ordering Method: Type No. (See the type number in the following table)

番号 Part No.	名称 Part Name	材質 Material	寸法 Size	規格 Standard	処理 Treatment
1	基板端子 Printed board Terminal	黄銅 Brass	板厚 t=1.0	C2680R	スズメッキ Tin-Plated
-	-	-	-	-	-

型番 Type No.	納入される物 Product Delivered
F4146H	基板端子 (Φ3.6) のみ Printed board terminal (for Φ3.6) only

対応可能ビス Compatible screw	材質 Material	処理 Treatment	形状 Shape
PW, SWセムスパイナド M4×7L Type③ With Plain (Flat) washer and spring lock washer M4×7L	鉄 steel	ニッケルメッキ Nickel-Plated	Type③
SWセムスパイナド M4×7L Type④ With spring lock washer M4×7L	鉄 steel	ニッケルメッキ Nickel-Plated	Type④
PW, SWセムスナベ M4×8L Type⑤ With Plain (Flat) washer and spring lock washer M4×8L	鉄 steel	ニッケルメッキ Nickel-Plated	Type⑤
SWセムスナベ M4×8L Type⑦ With spring lock washer M4×8L	鉄 steel	ニッケルメッキ Nickel-Plated	Type⑦