

ピッチ/Pitch 5.0mm



型名 Type Number	F6022
定格 Rating	AC250V 10A
絶縁抵抗 Screw Diameter	500V 1000MΩ以上 DC500V 1000MΩ and over
耐電圧 Usable Current	2000V 1分間以上 AC2000V 1minute and over
適合電線 Compatible Wire	本文をご参照下さい Refer to the text

一般公差/General Tolerance ±0.5

尺度/Scale 1/1 単位/Unit mm

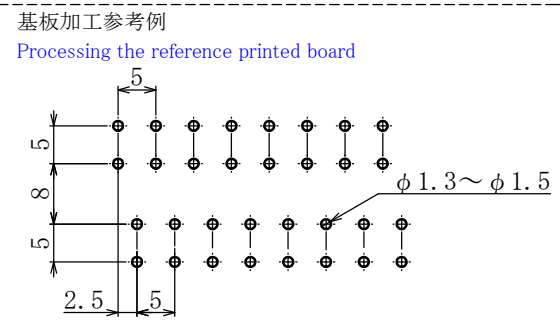
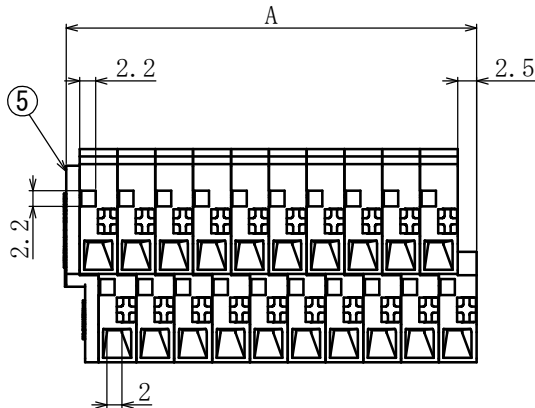

A・B寸法公差

2~20P	±0.5
22~30P	±0.7
32~40P	±0.8
42~50P	±1.0

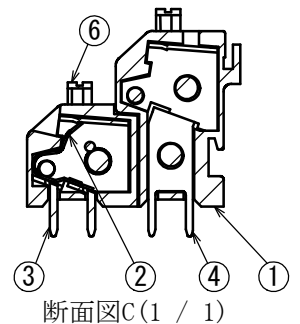
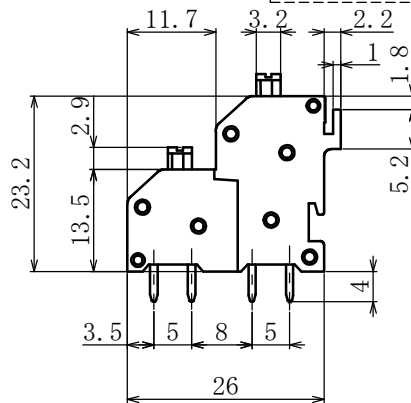
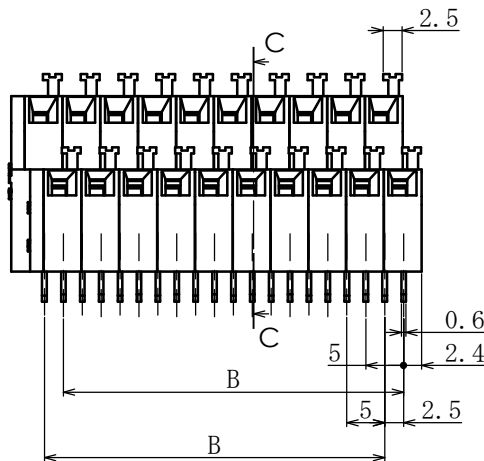

- ・注文方法: [型名]-----[極数]P.
- ・Ordering Form: Type No. No. of Poles (P)
- ・電線の接続、解除はマイナスドライバーで行う。
- ・The wire should be connected and disconnected with a minus driver.
- ・適合電線: φ0.65mm~1.6mm(単線)
- ・Compatible wire: φ0.65mm~1.6mm(Solid wire)
- ・線むき長さ: 7~10mm
- ・Stripped wire Length: 7~10mm
- ・最大通電電流5A時: 0.75m㎡
- ・Maximum current 5A: 0.75m㎡

■仕様/Specifications.

部番/Part No.	名称/Part Name	材質/Material	規格/Standard	寸法/Size	処理/Treatment	備考/Remarks
1	モールド Base	ナイロン66 Nylon66	UL94V-0			グレー Gray
2	ワイヤークランプバネ Wire clamp spring	ステンレス Stainless steel	SUS301-CSP-H	板厚 t=0.3		
3	接触板(A) Contact plate(A)	りん青銅 Phosphor bronze	C2680R-1/2H	板厚 t=0.6	スズメッキ Tin-Plate	
4	接触板(B) Contact plate(B)	りん青銅 Phosphor bronze	C2680R-1/2H	板厚 t=0.6	スズメッキ Tin-Plate	
5	エンドプレート End Plate	ナイロン66 Nylon66	UL94V-0			グレー Gray
6	ノブ Knob	POM	UL94V-HB			黒色 Black

極数/Poles	2	4	6	8	10	12	14	16	18	20	22	24	26	28	30	32	34	36	38	40	42	44
A	9.3	14.3	19.3	24.3	29.3	34.3	39.3	44.3	49.3	54.3	59.3	64.3	69.3	74.3	79.3	84.3	89.3	94.3	99.3	104.3	109.3	114.3
B	-	5.0	10.0	15.0	20.0	25.0	30.0	35.0	40.0	45.0	50.0	55.0	60.0	65.0	70.0	75.0	80.0	85.0	90.0	95.0	100.0	105.0

極数/Poles	46	48	50
A	119.3	124.3	129.3
B	110.0	115.0	120.0