

# 貫通型端子台

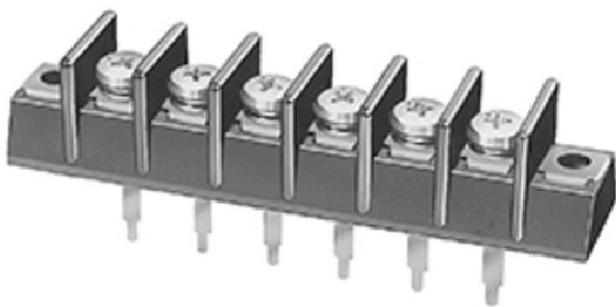

Through-type Terminal Block

ピッチ / Pitch 11mm



型名 Type Number	F2038A
定格 Rating	AC250V 20A
絶縁抵抗 Insulation Resistance	DC500V 1000MΩ以上 DC500V 1000MΩ and over
耐電圧 Withstands Voltage	AC2000V 1分間以上 AC2000V 1minute and over
ねじ径 Screw Diameter	M4
適合電線 Compatible Wire	2.0mm <sup>2</sup>

一般公差 / General Tolerance ±0.5

尺度 / Scale 1/1 単位 / Unit mm

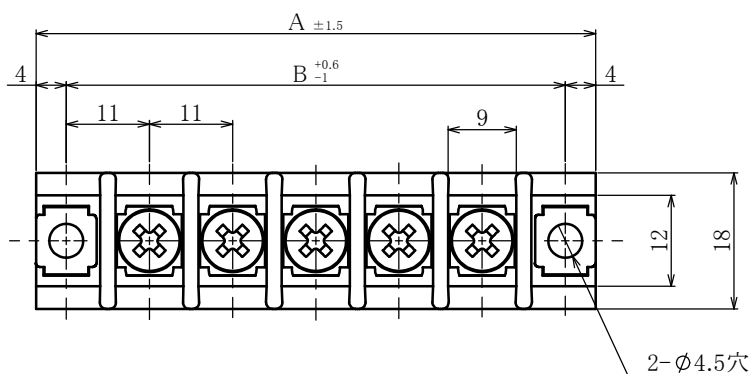

呼び / Nominal	L
4L	4
15L	15
20L	20
28.5L	28.5

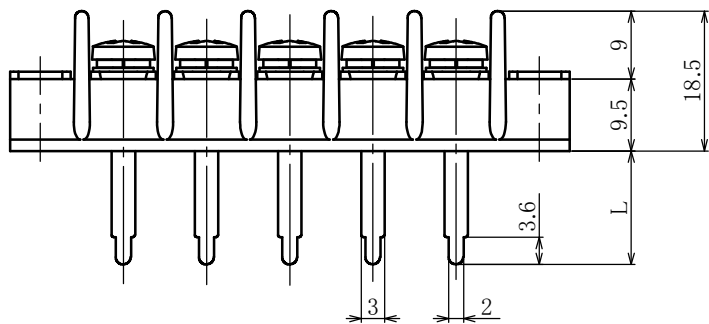
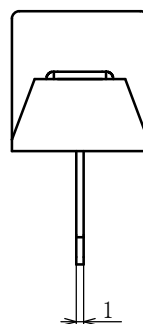
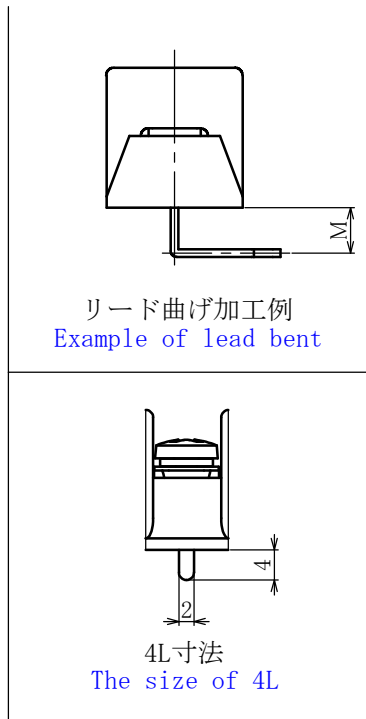

(曲げ希望時)

- ・ 注文方法 : 型名 ----- リード長 L ----- (曲げ希望時) 曲げ寸法 M ----- 極数 P.
- ・ Ordering Form: Type No.    Lead Length (L)    Bent Length (M)    No. of Poles (P)  
(if bending is desired)
- ・ 結線ビス : 締付けトルク 1.4N・m.
- ・ Connection screw: Tightening torque is 1.4N・m.
- ・ カバーはオプションとなっておりますので御希望の際は注文方法の末尾に-PCTとご記入下さい。(INDEX参照) 但しカバーは添付納入となります。その他オプション※ショートピース (F2113, F2113B)
- ・ The cover is optional. Purchasing method, add "-PCT(Cover)" at the end of the Part name. (See Index for reference) The cover will be delivered separately. Other options※Jumper (F2113, F2113B)

## 仕様 / Specifications.

部番 / Part No.	部番 / Part No.	材質 / Material	規格 / Standard	寸法 / Size	処理 / Treatment	備考 / Remark
1	モールド Base (A)	PBT	UL			黒色 Black
2	導電金具 Terminal	黄銅 Brass	C2680R	t=1.0	スズメッキ Tin-Plated	
3	結線ビス Screw	黄銅 Brass	C2700W	M4×0.7×8L	ニッケルメッキ Nickel-Plated	PW, SWセムスパインド Type③
4	取付金具 Mounting plate	黄銅 Brass	C2680R	t=1.0	ニッケルメッキ Nickel-Plated	

極数 / Poles	1P	2	3	4	5	6	7	8	9	10	11	12	13	14	15	16	17	18	19	20	21	22
A	30	41	52	63	74	85	96	107	118	129	140	151	162	173	184	195	206	217	228	239	250	261
B	22	33	44	55	66	77	88	99	110	121	132	143	154	165	176	187	198	209	220	231	242	253

極数 / Poles	23	24
A	272	283
B	264	275