

貫通型端子台

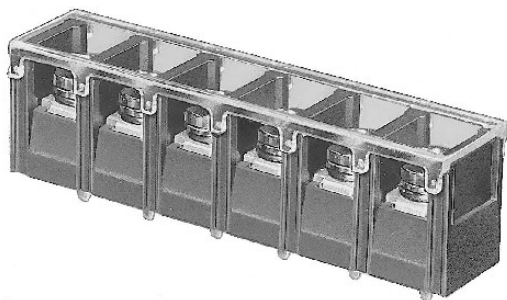

Through-type Terminal Block

ピッチ/Pitch 11mm



型名 Type Number	F 2 3 3 0 A X
定格 Rating	AC250V 20A
絶縁抵抗 Insulation Resistance	DC500V 1000MΩ以上 DC500V 1000MΩ and over
耐電圧 Withstands Voltage	AC2000V 1分間以上 AC2000V 1minute and over
ねじ径 Screw Diameter	M4
適合電線 Compatible Wire	2.0mm ²

一般公差/General Tolerance ±0.5

尺度/Scale 1/1 単位/Unit mm

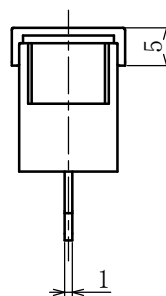
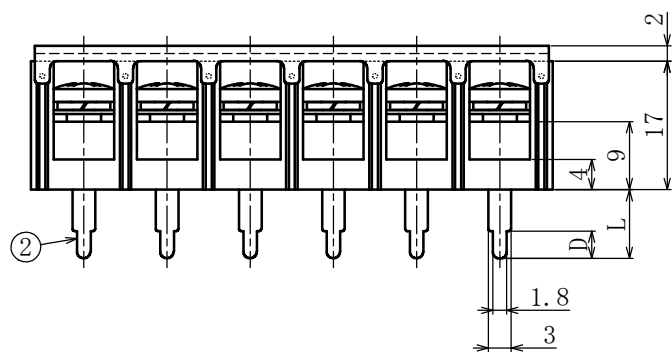
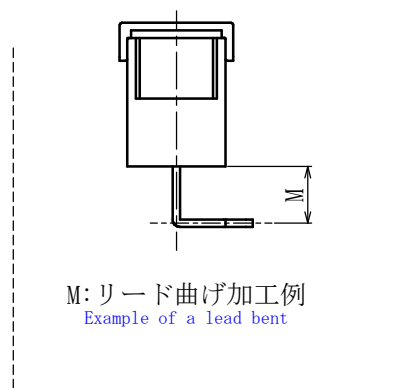
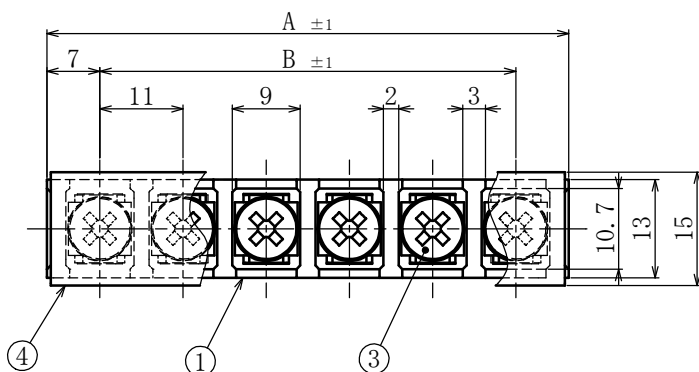

呼び/Nominal	L	D
4.5L	4.5	4.5
9L	9.1	3.6
12.5L	12.5	3.6
14L	14.0	4.0
20.5L	20.5	3.6
29L	29.0	3.6

- ・注文方法: 型名 — リード長L — (曲げ希望時) 曲げ寸法M — 極数 P.
- ・Ordering Form: Type No. Lead Length(L) Bent Length(M) No. of Poles(P)
(if bending is desired)

- ・結線ビス: 締付けトルク1.4N・m.
- ・Connection screw: Tightening torque is 1.4N・m.
- ・カバーはオプションとなっておりますのでご希望の際は注文方法の末尾に-CTとご記入ください。(INDEX 参照) 但しカバーは添付納入となります。その他オプション *ショートピース (F2121、F2113B、F2114) *補強金具 (F9015、F9097)
- ・A cover is optional. To obtain one, and "-CT" to the end of the order description shown above. (See INDEX for specifications) A cover will be delivered attached. Other options *Jumper (F2121, F2113B, F2114) *Mt. metal fitting (F9015, F9097)

仕様/Specifications.

部番 Part No.	名称 Part Name	材質 Material	規格 Standard	寸法 Size	処理 Treatment	備考 Remarks
1	モールド Mold	PBT	UL			黒色 Black
2	導電金具 Terminal	黄銅 Brass	C2680R	板厚 t1.0	スズメッキ Tin-Plated	
3	結線ビス Screw	黄銅 Brass	C2700W	M4×0.7×8L	ニッケルメッキ Nickel-Plated	PW, SWセムスハイント Type③
4	カバー Cover	ポリカーボネート Polycarbonate	UL		透明 Transparence	オプション Optional

極数/Poles	1P	2	3	4	5	6	7	8	9	10	11	12
A	14	25	36	47	58	69	80	91	102	113	124	135
B	—	11	22	33	44	55	66	77	88	99	110	121

極数/Poles	13	14	15	16	17	18	19	20	21	22	23	24
A	146	157	168	179	190	201	212	223	234	245	256	267
B	132	143	154	165	176	187	198	209	220	231	242	253